

No. 616,887.

Patented Jan. 3, 1899.

J. P. BROPHY.

LATHE ATTACHMENT FOR CUTTING IRREGULAR FORMS.

(Application filed Mar. 14, 1898.)

(No Model.)

2 Sheets—Sheet 1.

- FIG. I -

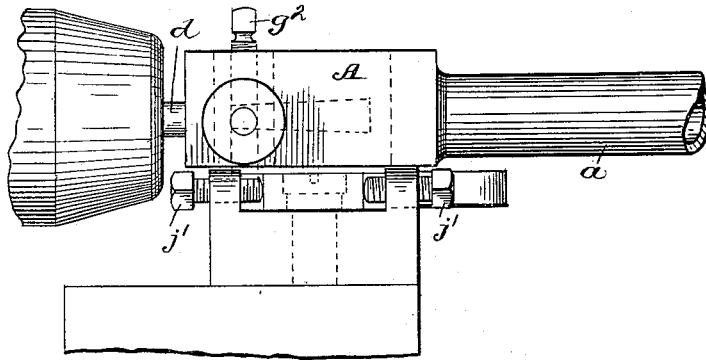

- FIG. II -

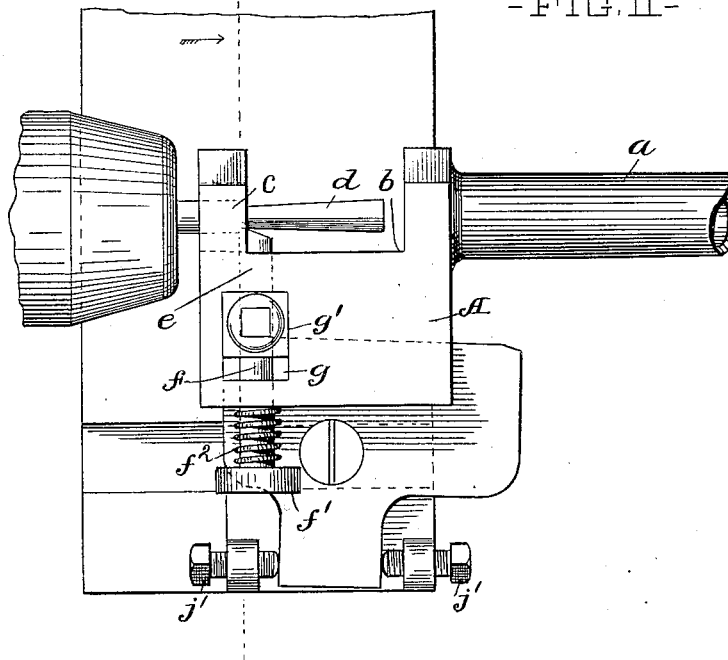

WITNESSES:

J. C. Turner
A. E. Merkel

INVENTOR

J. P. Brophy
BY
J. D. Fay
ATTORNEY.

No. 616,887.

Patented Jan. 3, 1899.

J. P. BROPHY.

LATHE ATTACHMENT FOR CUTTING IRREGULAR FORMS.

(Application filed Mar. 14, 1898.)

(No Model.)

2 Sheets—Sheet 2.

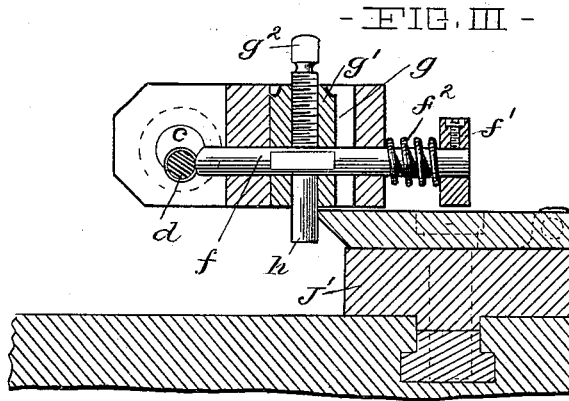

- FIG. IV -

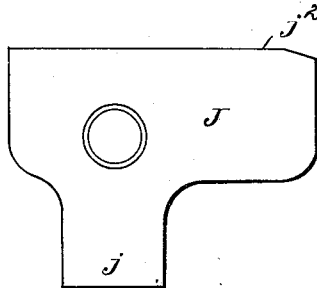

- FIG. V -

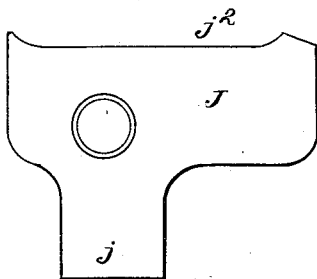

WITNESSES:

J. C. Turner
A. E. Merrill

INVENTOR

J. P. Brophy
BY
J. D. Fay
ATTORNEY.

UNITED STATES PATENT OFFICE.

JOHN P. BROPHY, OF CLEVELAND, OHIO, ASSIGNOR TO THE CLEVELAND MACHINE SCREW COMPANY, OF SAME PLACE.

LATHE ATTACHMENT FOR CUTTING IRREGULAR FORMS.

SPECIFICATION forming part of Letters Patent No. 616,887, dated January 3, 1899.

Application filed March 14, 1898. Serial No. 673,681. (No model.)

To all whom it may concern:

Be it known that I, JOHN P. BROPHY, a citizen of the United States, and a resident of Cleveland, county of Cuyahoga, and State of Ohio, have invented a new and useful Improvement in Attachments for Cutting Irregular Forms, of which the following is a specification, the principle of the invention being herein explained and the best mode in which I have contemplated applying that principle so as to distinguish it from other inventions.

My invention relates to an attachment for lathes and screw-machines, particularly automatic screw-machines, by means of which I am enabled on any machine of the character noted to make taper pins and other irregular forms.

The annexed drawings and the following description set forth in detail certain mechanism embodying the invention, such disclosed means constituting but one of various mechanical forms in which the principle of the invention may be used.

In said annexed drawings, Figure I is a front view showing my attachment secured in the chuck-head of a screw-machine. Fig. II is a plan view of the same. Fig. III is a transverse section taken on the line 3 3 of Fig. II and in the direction indicated by the arrow. Fig. IV is a plan of a former. Fig. V is a plan view of a former of different form.

My attachment consists of a box-mill A, of oblong form, having the spindle *a* integral therewith and cut away in its central portion *b*. A stock-opening *c* is provided in one of the cut-away portions, through which the stock *d* may pass in operation. A tool-opening *e* is formed transversely through the box-mill, and in said opening a cutter *f* is secured. A slot *g* is formed in the box-mill, and in said slot a slide *g'* is located, set-screw *g²* securing said tool *f* in said slide. A pin *h* is secured in the lower part of said slide and extends downwardly therefrom. The rear extension of the tool *f* is provided with an annular head *f'* and a spring *f²* is located intermediate of said head and the box-mill. The former *J* is secured to the cross-slide *J'* of the machine-frame by suitable means, is provided with the rearwardly-extending por-

tion *j*, and is held in adjustable position by means of set-screws *j'*. The edge *j²* of said former is practically a counterpart of one edge of the article to be formed.

The operation is as follows: The box-mill is secured in the machine by means of spindle *a*. One side of the machine and the former is properly secured to the cross-slide. The stock to be operated upon is secured in the chuck-head and passes through the opening *c* of the box-mill, rotating against the cutting-tool *f*. The operation of the machine advances the box-mill toward the chuck-head holding the stock to be operated upon. The depending pin *h*, having bearing against the edge *j²* of the former *J*, causes the cutting edge of the cutting-tool in its forward movement to move on a line parallel with and in conformation to the outline of the edge *j²* of the former.

By means of the set-screw *g²* the cutting-tool may be adjusted forwardly or rearwardly, as desired. The opening *c* in the box-mill acts as a guide-rest for the stock to be operated on, preventing springing of the stock. Spring *f²* exerts rearward pressure on the cutting-tool and tends to keep pin *h* in engagement with the edge of the former, the slide *g'* having easy movement in the slot *g*.

It will be seen that by means of this attachment any irregular form can be cut out on a lathe or screw-machine, whether automatic or otherwise, by merely securing the attachment in proper position and providing it with a former of proper contour for the work to be made.

Other modes of applying the principle of my invention may be employed instead of the one explained, change being made as regards the mechanism herein disclosed, provided the means covered by any one of the following claims be employed.

I therefore particularly point out and distinctly claim as my invention—

1. In an attachment for cutting taper pins and articles of irregular form, the combination of a box-mill provided with a recess, a tool-holder located in said recess and having sliding movement therein, said tool-holder having a depending lug adjustable longitudi-

nally of said tool, and a former substantially in counterpart of the article to be operated upon, substantially as set forth.

2. In an attachment for cutting taper pins and articles of irregular form, the combination of a box-mill having a tool-opening and provided with a recess, a tool-holder located in said recess and having sliding movement therein, said tool-holder having a depending lug adjustable longitudinally of said tool and a former substantially in counterpart of the article to be operated upon, substantially as set forth.

3. In an attachment for cutting taper pins and articles of irregular form, the combination of a box-mill provided with a stock-opening,

a tool-opening and a tool-holder opening, said stock-opening and tool-opening located in juxtaposition and substantially at right angles to each other, a tool-holder located in said tool-holder opening and through which said tool passes, said tool-holder adjustable longitudinally of said tool and provided with a depending lug, a former adjustable relatively to the article to be operated upon and engaging with said tool-holder lug, substantially as set forth.

Signed by me this 11th day of March, 1898.
JOHN P. BROPHY.

Attest:

D. T. DAVIES,
A. E. MERKEL.